

# Specification Data

## Panasonic Ventilation Fan

**Panasonic**

*WhisperFit™*  
VENTILATION FAN



**FV-08VF2 (80 CFM)**

### Description

Ventilating fan shall be Low Noise ceiling mount type rated for continuous run. Fan shall be ENERGY STAR rated and certified by the Home Ventilation Institute (HVI). Evaluated by Underwriters Laboratories and conform to both UL and cUL safety standards.

### Motor/Blower:

- Four-pole totally enclosed condenser motor rated for continuous run.
- Power Rating shall be 120 volts and 60 Hz.
- Fan shall be UL and cUL listed for tub/shower enclosure when used with a GFCI branch circuit wiring.
- Motor equipped with thermal-cutoff fuse.
- Removable with permanently lubricated plug-in motor.

### Housing:

- Rust proof paint, galvanized steel body.
- 4" diameter duct with optional 3" adapter included.
- Built in backdraft damper.
- Double hangar bar system allowing for ideal positioning.

### Grille:

- Attractive design using PP material.
- Attaches directly to housing with torsion springs.

### Warranty:

- The factory warranty shall be a minimum of 3 years limited warranty on parts.

### Typical Specifications:

Ventilating fan shall be of the ceiling mount. ENERGY STAR rated type, with no less than 80 CFM and no more than 0.8 sones as certified by the Home Ventilating Institute (HVI) at 0.1 static pressure in inches of water gauge when used with the 4" duct. Power consumption shall be no greater than 24.5 watts and ENERGY STAR rated with efficiency rating of no less than 3.3 CFM/watt. The motor shall be totally enclosed, four pole condenser type engineered to run continuously. Power shall be 120v/60Hz. 3" duct adapter available with performance specifications as listed in the specification chart below. Fan shall be UL and cUL listed for tub/shower enclosure when used with GFCI branch circuit wiring.

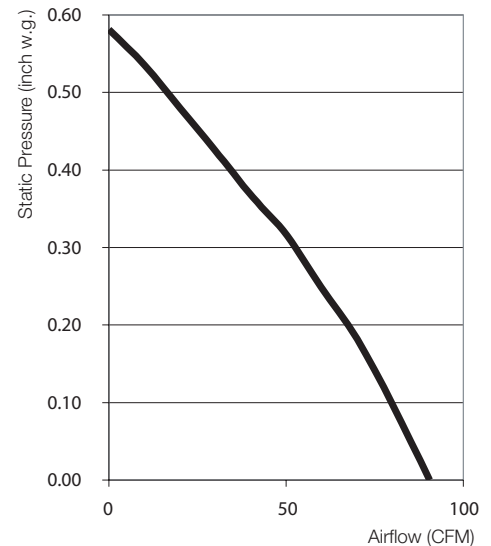
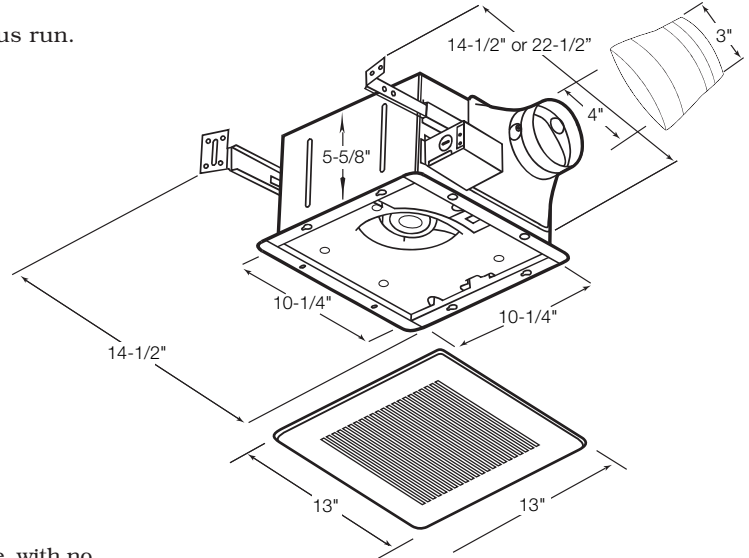

### Specifications:

<b>FV-08VF2</b>		<b>4" Duct (Standard)</b>		<b>3" Duct (Optional)</b>	
<i>Ventilation Fan Characteristics (HVI Certified Data)</i>	Static Pressure (inches w.g.)	0.1	0.25	0.1	0.25
	Air Volume (CFM)	80	60	70	53
	Noise (sones)	0.8	NA	0.8	NA
	Power Consumption (Watts)	24.5	24.3	24.3	24.0
	Energy Efficiency (CFM/Watts)	3.3	2.5	2.9	2.2
	Speed (RPM)	757	956	845	1007
	Current (amps)	0.20	0.20	0.20	0.20
	Power Rating (V/Hz)	120/60			

For Complete Installation Instructions Visit [www.panasonic.com/building](http://www.panasonic.com/building)



Model	Quantity	Comments	Project:
			Location:
			Architect:
			Engineer:
			Contractor:
			Submitted by:
			Date: